

Step 1: Materials Needed for an OEM Assembly

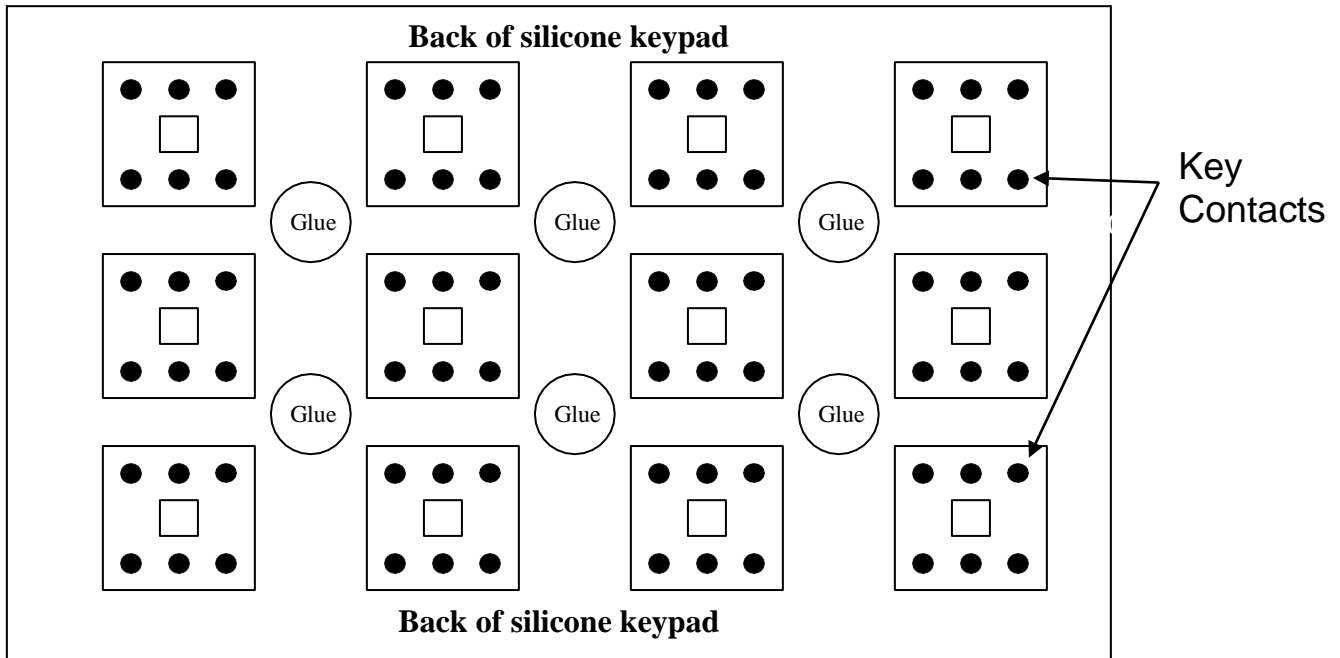

1. OEM Printed Circuit Board
2. Silicone Rubber Keypad Overlay
3. Cable
4. Silicone RTV Glue

Step 2: Applying Adhesive to Silicone Overlay



Apply silicone adhesive [iKey recommends SuperFlex by Loctite] to back side of silicone overlay (keypad). Sparingly dab glue on the middle of each key intersection across the whole keyboard as seen in this picture. Also apply to inside of center portion of HulaPoint™ pad (where the sensor/joystick lies) if OEM kit incorporates the HulaPoint™

Be careful not to drop silicone on any key contacts.

INCORRECT GLUING PROCEDURE

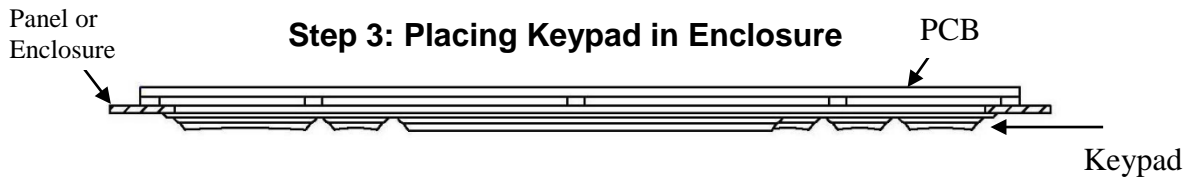
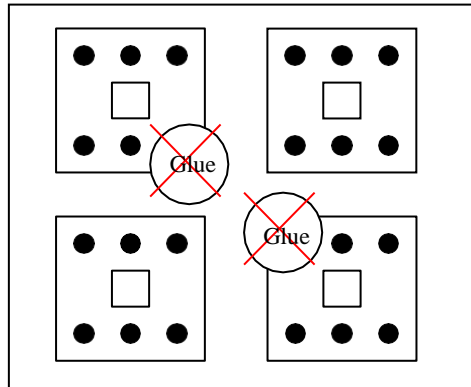

1. Put the silicone rubber keypad into place on the panel or enclosure you are using. Do not place PCB yet.
2. Seat the keypad in the mounting cutout by sliding one edge at a time into the cutout space.
3. Spread the keypad to be sure it is well seated on all four sides. Ensure that the lip is through the cutout all the way around the pad.
4. When the keypad is in place, gently allow the board to fall into place on top of the keypad so no glue is displaced onto a key trace, or key contact. (**Note:** make sure the PCB and pad are oriented in the same direction.)

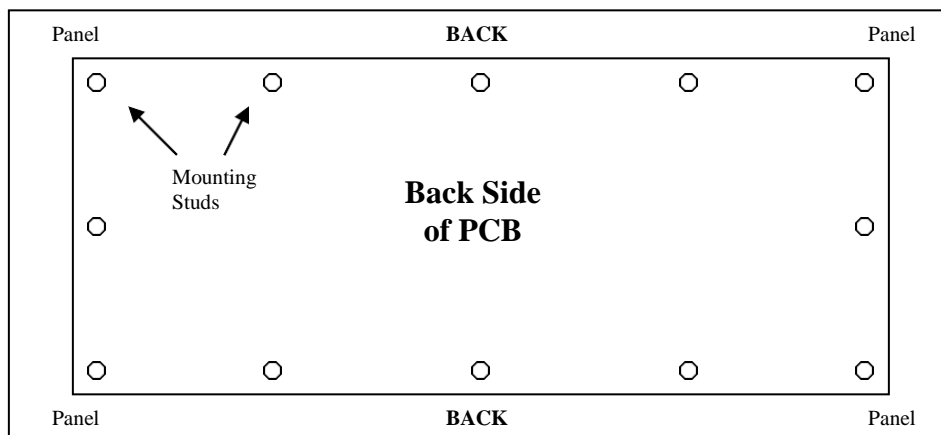

5. Tighten hex nuts until keypad is just **SLIGHTLY** compressed between panel and PCB. We recommend 1.5 in/lbs. of torque when tightening.
6. Run fingers between all keys to ensure a good silicon and PCB bond.
7. Allow glue to cure for 1 hour

Step 4: Wiring for Keyboard

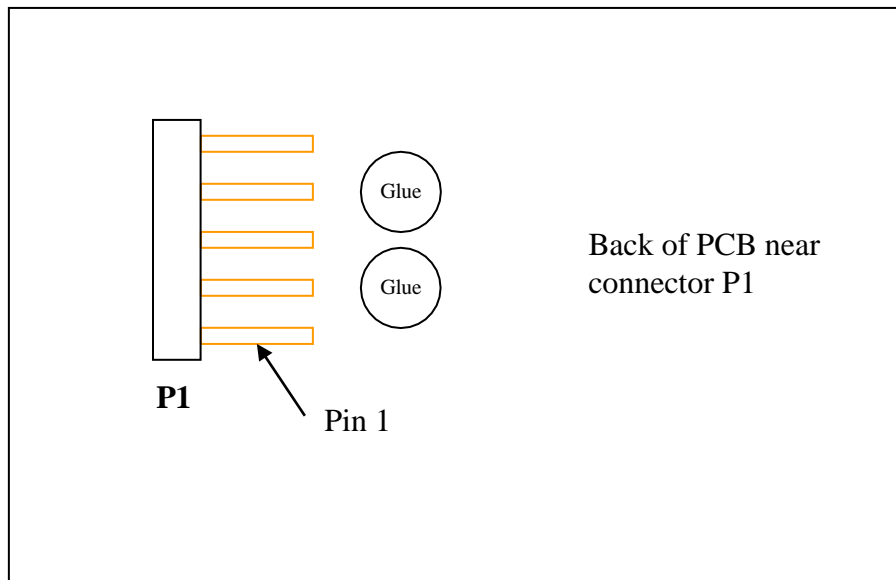

Add a dab or two of glue on the PCB just in front of the connector so that the cable header will sit on the glue when connected to the board and make itself more secure. The picture above illustrates the placement of the glue prior to the connection

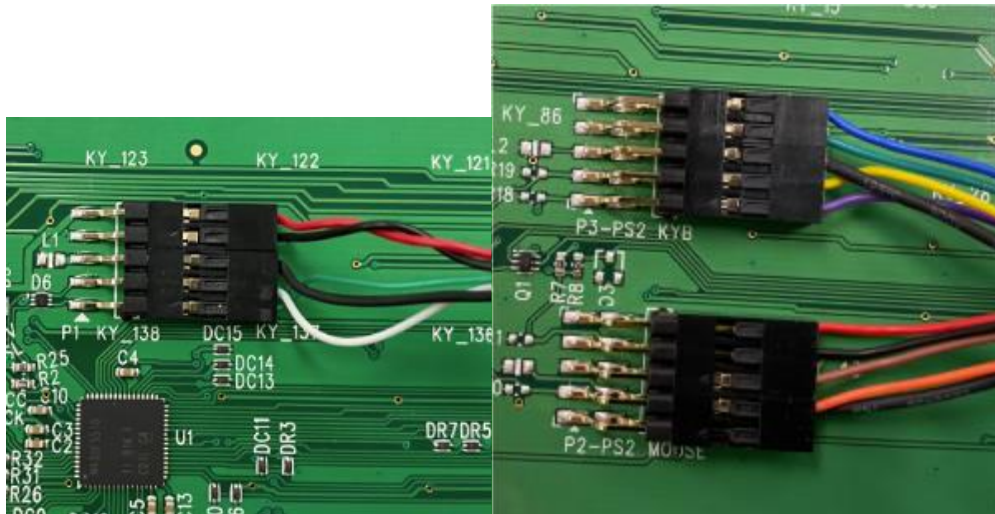

USB Cable: Green, White, Matte Black, Black, Red

PS/2 Cables: P2 (Orange, Matte Black, Brown, Black, Red), P3 (Purple, Yellow, Matte Black, Teal, Blue)

Custom Cables Signal Layout

USB		
P1 (1x5 Header)		
PIN	Connectivity Function	Color
1	D+	Green
2	D-	White
3	Chassis Ground	Matte Black
4	Signal Ground	Black
5	Power (+5 VDC)	Red

PS/2 Keyboard		
P3 (2x5 Header)		
PIN	Connectivity Function	Color
1/2	PS2 KYB Clock	Purple
3/4	PS2 KYB Data	Yellow
5/6	Chassis Ground	Matte Black
7/8	Signal Ground	Green
9/10	Power (+5 VDC)	Blue

PS/2 Mouse		
P2 (1x5 Header)		
PIN	Connectivity Function	Color
3	PS2 MOU Clock	Orange
4	Chassis Ground	Black
5	Signal Ground	Brown
8	PS2 MOU Data	Black
10	Power (+5V DC)	Red

Your iKey unit is now ready to use with your set up.

If you should have any additional questions, please feel free to contact iKey directly at (800) 866-6506 or send an email to support@ikey.com